

Build Over or Near a Council Pipe or Drain Application Form

MAY BE EITHER WASTEWATER, STORMWATER OR WATER SUPPLY PIPES

About this form

No building shall be constructed over any of the Council's pipelines, within a Council easement for services, nor shall any structure foundation be located within a line extending 45 degrees upwards from 150mm depth below the pipe invert from the edge of the trench to the ground surface, without the specific approval of the Council. What information does Council require?

Zone of Influence Triangular No Load Zone

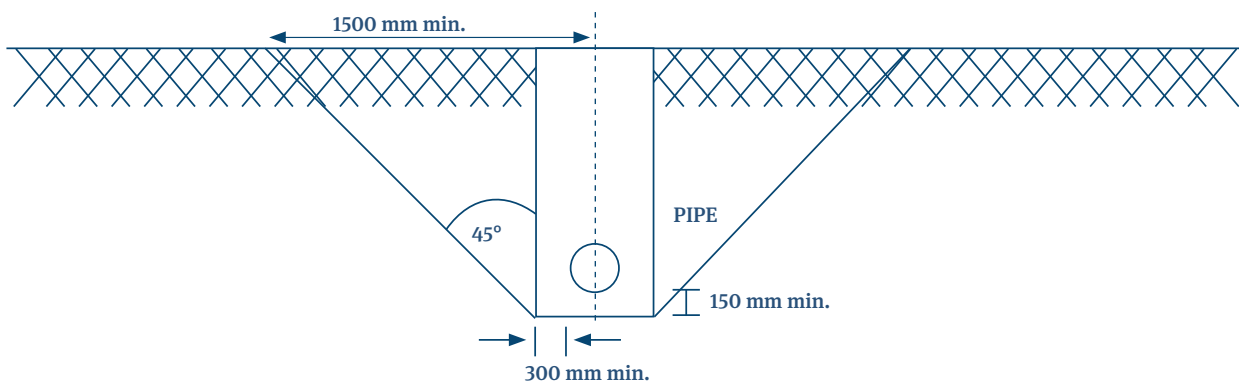

If there are drains owned by the Council within or adjacent to your property that may be affected, please check this out at the pre-design stage so your project is not delayed. Council pipes may be wastewater, stormwater or water.

When can I build over services?

The Council will only give approval to construct a structure over infrastructure services if:

- It is impractical to construct a new main or relocate the building, clear of the zone of influence; and
- The pipe runs in a straight line both vertically and horizontally between manholes; and
- There are no connections under the building; and
- The condition of the pipe is checked by CCTV prior to construction and the pipe condition is approved as acceptable by the Council; and
- Structures straddling or founded within the above zone are designed by a Chartered Professional Engineer such that there is no loading to the pipeline.
- A memorandum of encumbrance is created, if required by the Council, indemnifying the Thames-Coromandel District Council against any claims for damage caused by the presence, maintenance, replacement, or upgrade of the pipeline.

Who pays?

Section 451 of the Local Government Act 1974 states:

- 1) If any person proposes to erect any building or to carry out any work in such a location and at such levels that the diversion, alteration, protection, or replacement of any drainage works of Council appears to be essential to the erection of the building or carrying on of the work:
 - a) That person shall notify Council of his proposals; and
 - b) If Council is satisfied that it is practicable for its drainage works to be diverted, altered, protected, or replaced without material interference with the services for which it is responsible and that it is reasonable that this can be done, it may enter into an agreement with that person as to the manner in which the drainage works shall be diverted, altered, protected, or replaced.
- 2) The cost of so diverting, altering, protecting, or replacing the drainage works of Council shall be borne by that person, and all other cost.
- 3) If that person fails to comply with any condition specified in any such agreement, he commits an offence against this Act.

You will need to cover any costs to the Council of:

- CCTV condition surveys; and
- Changes to any easement documents, if necessary; and
- Memorandum of Encumbrance expense, if necessary; and
- Design and construction work to move or change the assets in any way.

Submitting an application

- Submit your application to the **Infrastructure Manager** by email to customer.services@tcdc.govt.nz
- Post an application to Infrastructure Manager, Thames-Coromandel District Council, 515 Mackay Street, Thames 3540
- Hand deliver applications to Thames, Whangamata, Whitianga or Coromandel offices.

Plans

Details of existing Thames-Coromandel District Infrastructure service locations can be viewed directly by visiting www.tcdc.govt.nz and clicking on “Maps (GIS)” and then selecting “Map”. This will allow viewing of Council-managed infrastructure in your area but does not include easement information. (Please note that Council's GIS is indicative only.) If you have a copy of a PIM or obtain one from Council this may assist identifying services and easements on your site. A physical locate of the public service in question can be undertaken by Council's Operations Contractor in order to confirm the pipe location, material and depths. Should you require this service you will need to undertake a request for service through Council's Customer Services 07 868 0200 or customer.services@tcdc.govt.nz. The information that you receive from Council's Operations Contractor must accompany your application form.

Easements

Easements for public infrastructure grant rights that provide Council with the right to work on and replace a pipe if and when necessary. You will need to identify where easements for Council services are located on your property. These are registered on your property Certificate of Title and your lawyer will be able to assist with obtaining relevant title and easement data. The easement prevents the landowner from placing structures and/or landscaping within the easement area without prior approval from the Council. If you want to place any structure within the easement then the easement terms must be varied to reflect the fact that Council has given approval, and to reflect that Council's obligations with respect to making good any damage caused as a result of it exercising its rights does not apply to the repair of any structures erected within the easement area.

CCTV

A CCTV survey of existing drains (waste and storm water only) to be carried out by a suitably qualified person at the applicant's expense. Depending on the risk to the pipe during construction a further CCTV survey may also be required at the cost of the applicant. Any damage will be the responsibility of the applicant.

Process - how to proceed with your project

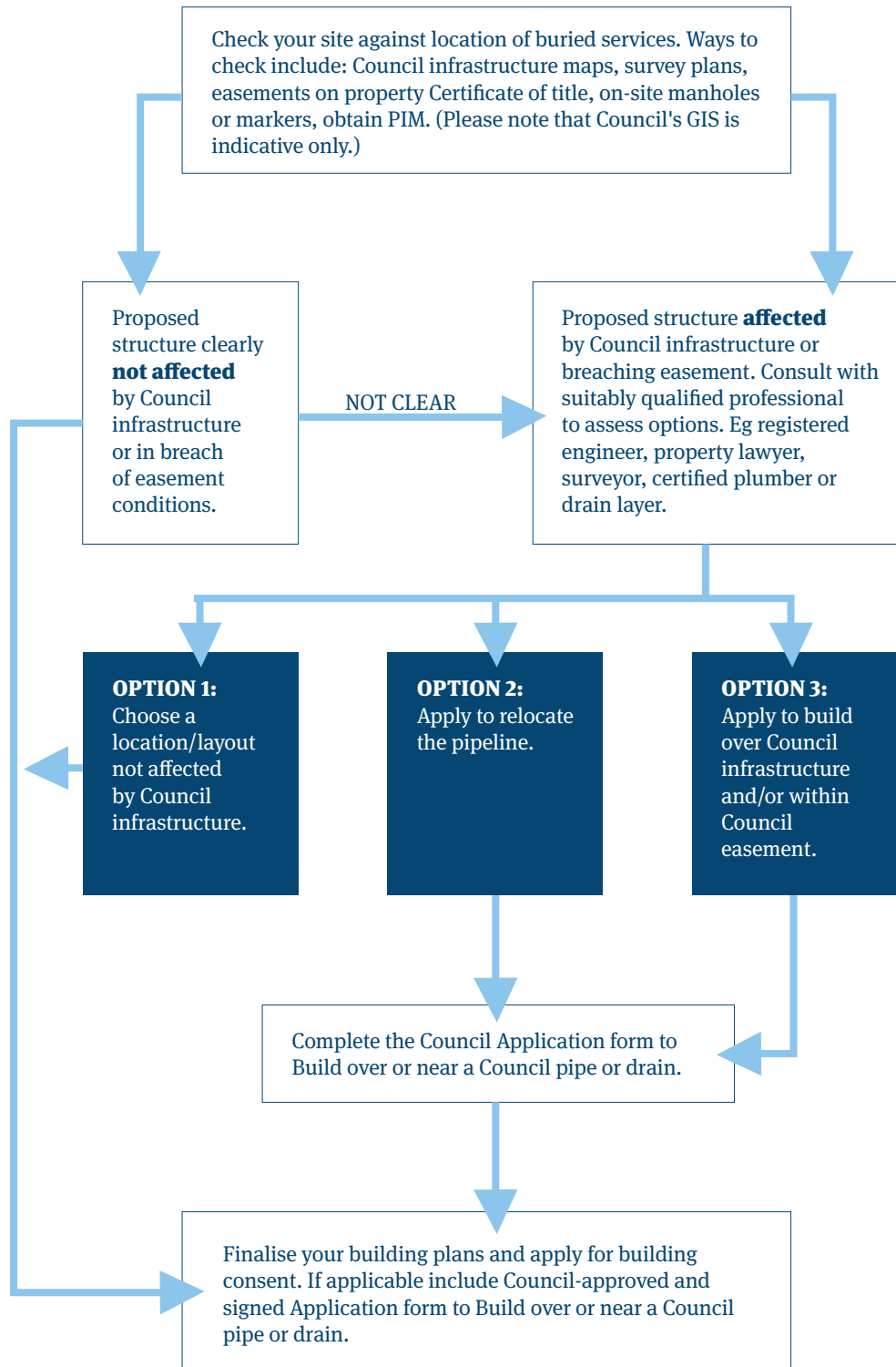

Build Over or Near a Council Pipe or Drain Application Form



Please use this form should you wish to apply to build over or relocate Council infrastructure services within your land. All applications will be checked for completeness prior to acceptance. Please ensure that you have compiled your documents completely to avoid delays in acceptance of your application. If your application is incomplete it will not be accepted and any statutory processing timeframes will not start until the missing information has been provided.

Applicant and land details

Owner's name	Signature	Date
Address of property		
Legal description		
Owner's postal address		
Contact name <i>(if not owner)</i>	Signature	Date

Are you seeking to build over or redirect a Council pipe/drain? YES NO

Explain why you wish to build over or near a Council Pipe or drain?

Provide plans which clearly show:

- Distance between the proposed building/structure and all legal boundaries; and
- Distance between the proposed building/structure and any existing buildings; and
- Distance from public drain(s), manhole centre(s) to all legal boundaries; and
- Location of any council pipes or drains within site; and
- Easement boundaries; and
- Depth of the buried pipeline (if known)
- Dimensions and location of the proposed building/structure, including foundation design details adjacent to pipes; and
- Provide the results or a copy of any CCTV surveys already undertaken

Fees

There is a standard application fee of \$650 deposit that is the responsibility of the applicant. This covers all direct and indirect costs from the Thames-Coromandel District Council in; processing the application, infrastructure changes, legal fees, changes to titles and/or easements, CCTV surveys etc. An hourly rate of \$180/hr will be charged per application with the deposit being utilised before additional charges incurred.

Payment details

Provide payment method for costs associated with this application

**Office
use only**

DECISION OF THE COUNCIL'S INFRASTRUCTURE MANAGER:

NAME

INFRASTRUCTURE ENGINEER

DATE