

PIPE CROSSING UNDER ROAD

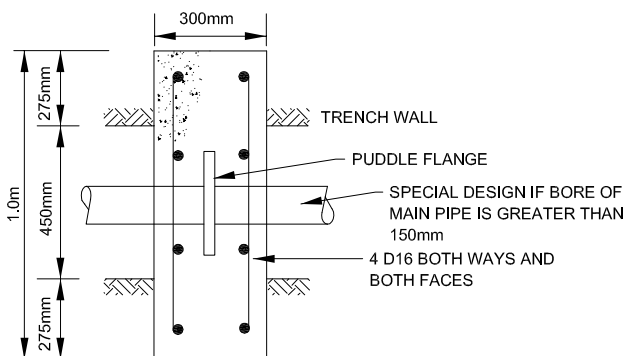

SECTION A-A

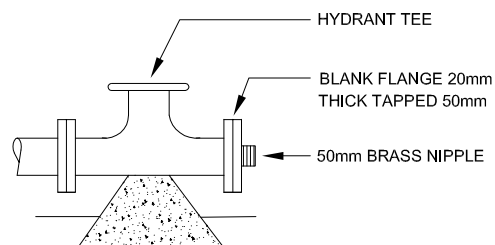

ALTERNATIVE TO A FLANGED REDUCER

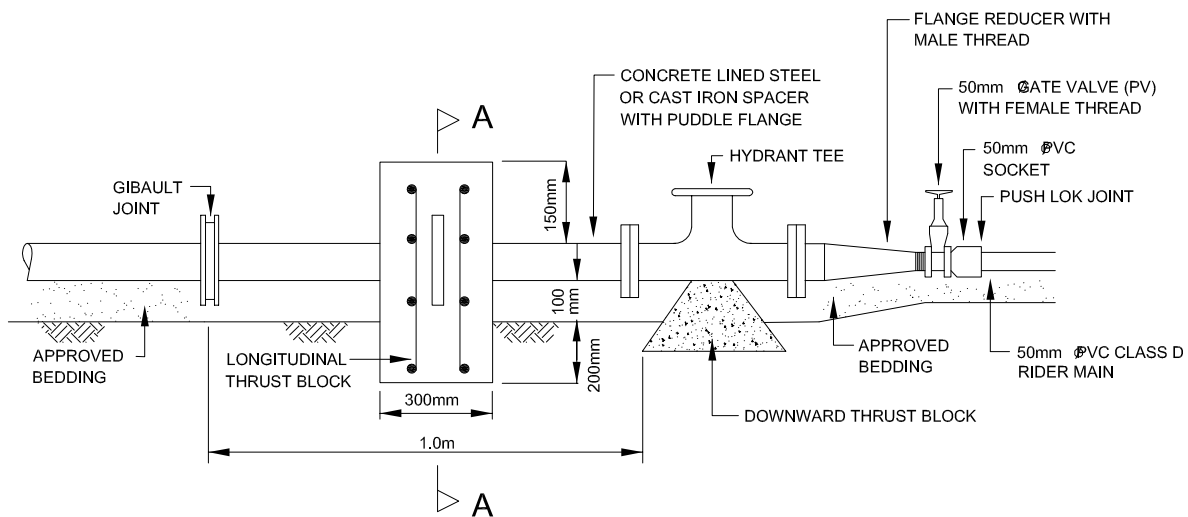

TYPICAL REDUCTION TO A 50mm RIDER MAIN

NOTE:-

1. Specific design of thrust block by Developers Engineer.



STANDARD DETAIL:

**PRINCIPAL MAIN
TO RIDER MAIN
CONNECTIONS**

DATE: June 2010

NOT TO SCALE

TCDC NO:

SHEET NO:

REV:

4000

2